

ERNI ATCA

Zone 1 Power Connector acc. to PICMG 3.0

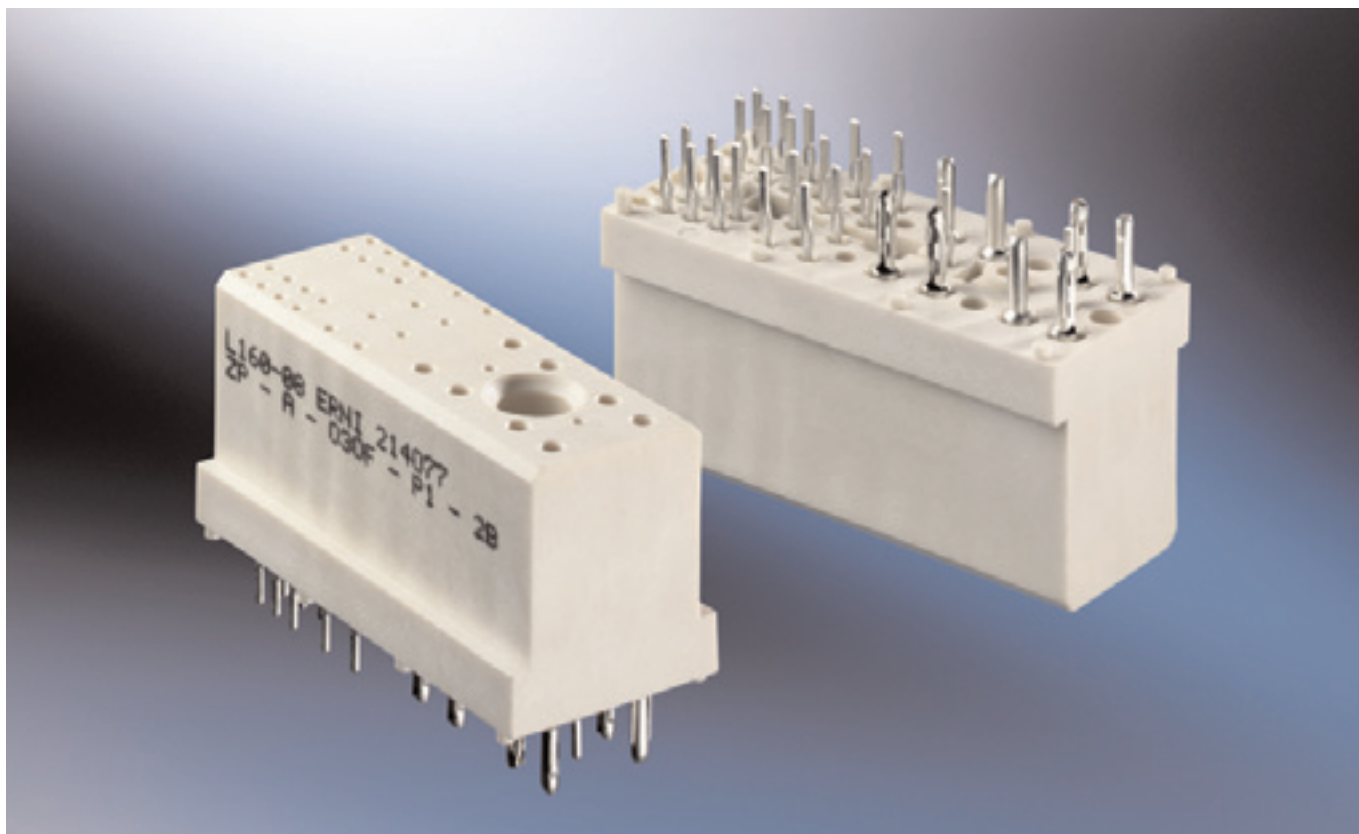

ERNI is anxious to support customers extensively and is gradually completing the product range for interconnect platforms. This also includes the ATCA (Advanced Telecom Computing Architecture) standard. This standard (also known as PICMG 3.0) is one of the latest standards addressing future telecommunication needs. ERNI can supply both power and signal connectors.

According to PICMG 3.0 the AdvancedTCA Power Connector is qualified for use in Zone 1. The connector consists of 8 size 16 contacts along with 22 size 22 contacts. The insulation body has an integrated guiding feature. The contact terminals provide compliant pressfit zones for easy assembly to the PCB. The reliability of the pressfit technology has been proven many times in long term field experiences. The pressfit zones are flat-rock compatible, there is no need for special press-in tools. The excellent design fully avoids any risk of damaging the connector during the press-in process.

The use of high conductivity copper alloy allows high current carrying capability. The power contacts are capable of carrying 16A and each signal contact is capable of carrying 2A. The female contacts' „lead in“ design combined with cavity protection prevent the contacts from being damaged.

Contacts which were plated subsequently do not have any bare ends and therefore are suitable for long term usage in critical environments. A mounting screw (customer supplied) may be used, but is not necessarily required. The connector meets all PICMG 3.0 performance requirements and is fully intermateable

with alternative connectors which were designed according to the same standard.

Features

- In accordance with the PICMG 3.0 standard
- Gold over nickel plating in contact area, tin plating on pcb terminals.
- Controlled plating thickness at female mating point
- RoHS compliant
- Stamped female contacts with high conductive material for highest current carrying capacity
- Improved normal contact force and relaxation compared to machined contacts
- Reliable and proven pressfit zone
- Standard flat rock press-in tools
- No additional pcb retention hardware required
- Female contacts fully protected through proven lead-in design
- Positions 1, 2, 3 and 4 are not loaded
- For specific applications partial contact loading is possible

PICMG 3.0 Partnumber: ZP-A-030F-P1-2B
ERNI Partnumber: 214077



Electrical And Mechanical Characteristics

Technical data

Temperature range	-55/125°C	
Current rating	Pos. 5-24, 27, 32	2 A
	Pos. 25, 26, 28-31, 33, 34	16 A
Clearance and creepage distance	Pos. 5-16	min. 0.7 mm
	Pos. 17-24	min. 2.5 mm
	Pos. 25-26	min. 5.5 mm
	Pos. 27-34	min. 1.4 mm
	Pos. 13-16 to 17-20	min. 3.0 mm
	Pos. 21-24 to 25, 26	min. 4.0 mm
	Pos. 25, 26 to 27-29	min. 2.0 mm
Voltage rating	Has to be determined according to client-specific using case (degree of environmental pollution) according to IEC 60664.	
Dielectric strength	Pos. 1-16	1000 V _{rms}
	Pos. 17-24	2000 V _{rms}
	Pos. 25-34	2000 V _{rms}
Contact resistance	< 20 mΩ	
Insulation resistance	> 10 ⁴ MΩ	

Materials

Housing: Plastic material (symbol)	PA 46 GF 30
CTI value	CTI 225
UL flame rating	UL 94 V-0
UL file (plastic material)	E47960

Contact and mating area

Base Material	Cu alloy
Plating	0.8 μm Au over 2-3 μm Ni

Termination area

Base Material	Cu alloy
Plating	0.5-2 μm Sn matt over 2-3 μm Ni

Environment compatibility

Recycling	no flame-retardent additives, no toxic additives allow easy recycling
-----------	---

Dimensional Drawing

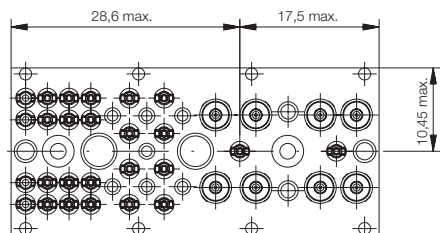

Bestückungsplan / contact assembly

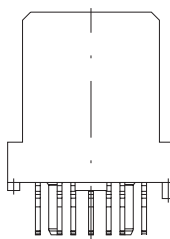
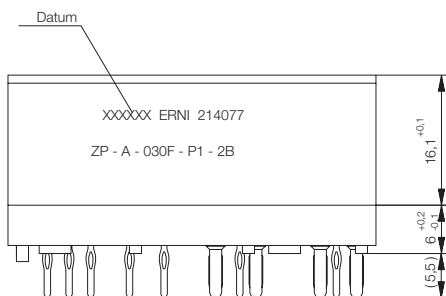
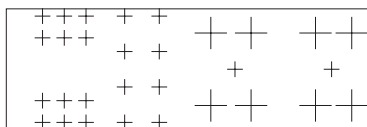

Verpackt in Tray tray packaging
Verpackungseinheit: 32 St. packaging unit 32 pcs

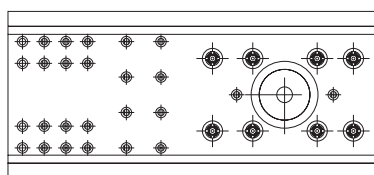
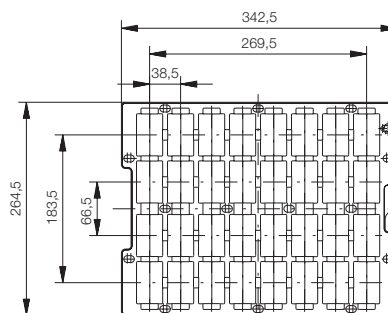

PCB Layout

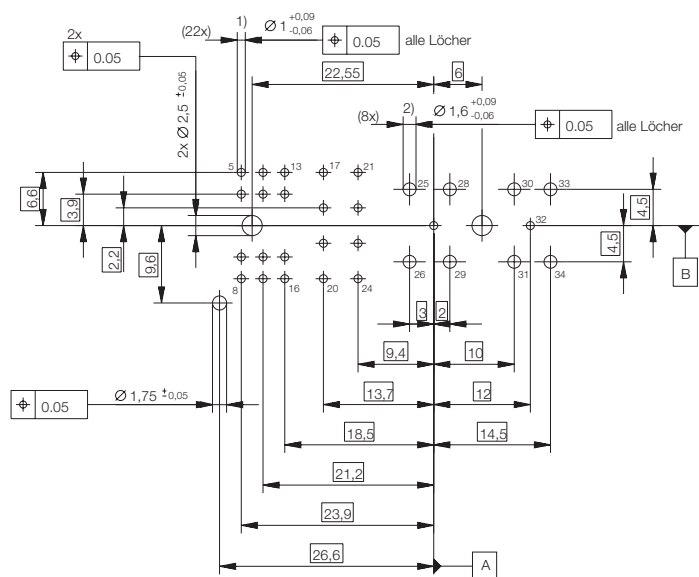

Schichtaufbau im metallisierten Loch $\varnothing 1$ siehe Zeichnung 164062 Nr. 6 oder 114124
diameter of drilled hole $\varnothing 1$ see drawing 164062 no. 6 or 114124

Schichtaufbau im metallisierten Loch $\varnothing 1,6$ siehe Zeichnung 164062 Nr. 10 oder 114407
diameter of drilled hole $\varnothing 1,6$ see drawing 164062 no. 10 or 114407

- 1) $\varnothing 1,0 \begin{smallmatrix} +0,09 \\ -0,06 \end{smallmatrix}$ Durchmesser des metallisierten Loches
 $\varnothing 1,0 \begin{smallmatrix} +0,09 \\ -0,06 \end{smallmatrix}$ diameter of finished plated-through hole
- 2) $\varnothing 1,6 \begin{smallmatrix} +0,09 \\ -0,06 \end{smallmatrix}$ Durchmesser des metallisierten Loches
 $\varnothing 1,6 \begin{smallmatrix} +0,09 \\ -0,06 \end{smallmatrix}$ diameter of finished plated-through hole

Fehlende Angaben siehe PICMG 3.0 / missing information see PICMG 3.0