

STANDARD CHARACTER MODULES

YMS162-21

16CHAR x 2LINE
1/16DUTY, 1/4BIAS

1 EXTERNAL DIMENSION AND DISPLAY PATTERN

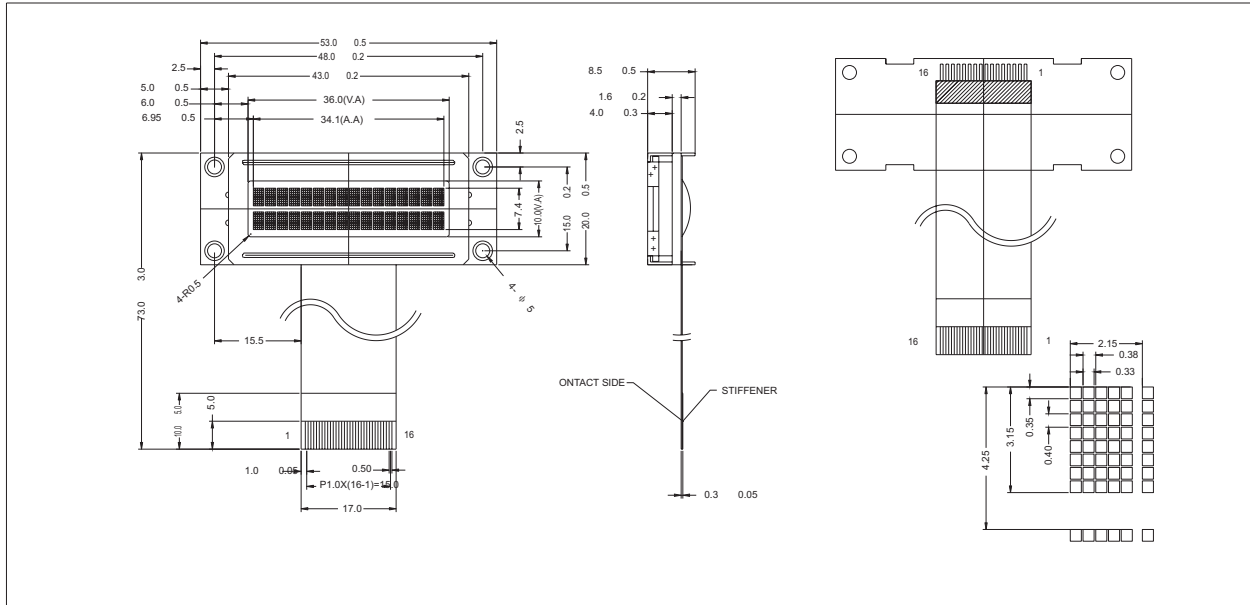

2 MECHANICAL DATA

ITEM	SPECIFICATION	UNIT
Module Size(W*H*T)	53.0 20.0 8.5	mm
Viewing Area(W*H)	36.0 10.0	mm
Character Font(W*H)	5 7 with Cursor	mm
Character Size (W*H)	1.85 3.15	mm
Character Pitch (W*H)	2.15 4.25	mm
Dot Size (W*H)	0.33 0.35	mm

3 PIN CONFIGURATION

PIN	SYMBOL	SIGNAL DESCRIPTION
1	V _{SS}	GND (0V)
2	V _{DD}	Power Supply (5V)
3	V _{EE}	Supply Voltage LCD Driver
4	RS	Register Select-LOW=Instruction, HIGH=Data
5	R/W	Read/Write LOW=MPU to LCM, HIGH=LCM to MPU
6	E	Eable R/w=LOW;Data are talking over at falling edge R/w=HIGH;Data can be read at E=1
7 to 14	DB ₇ to DB ₀	Data Bus-Software Selectable 4 or 8bit Mode
15	LED+	Anode of LED Unit
16	LED-	Cathode of LED Unit

4 ABSOLUTE MAXIMUM RATINGS

PARAMETER	SYMBOL	MIN	MAX	UNIT
Supply Voltage Logic	V _{DD} -V _{SS}	-0.3	7.0	V
Supply Voltage Driver	V _{DD} -V _{EE}	-0.3	13.5	V
Intut Voltage	V _{IN}	-0.3	V _{DD} +0.3	V

Operating Temp	See page 9
Storage Temp	

5 ELECTRICAL CHARACTERISTICS(Ta=25 °C)

ITEM	SYMBOL	CONDITION	SPEC. VALUE			UNIT
			MIN.	TYP.	MAX.	
Supply Voltage (Logic)	V _{CC} -V _{SS}		4.5	5.0	5.5	V
Supply Current (Logic)	I _{DD}	V _{CC} =5V	-	0.8	2.0	Ma
Input Voltage	HIGH	V _H	-	2.2	-	V _{DD}
	LOW	V _L	-	-0.3	-	0.6
Output Voltage	HIGH	V _{OH}	I _{OH} =1.2mA	2.4	-	V
	LOW	V _{OL}	I _{OL} =1.2mA	-	-	0.4
LCD Operating Voltage	V _{CC} -V _{EE}	V _{DD} =5V Ta=25 °C	-	4.4	-	
Supply Voltage LCD Drive	I _{EE}		-	1.0	-	

6 BLOCK DIAGRAM

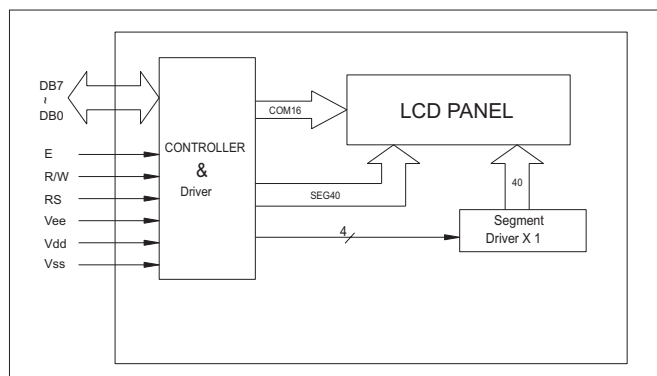

7 BACKLIGHTING CHARACTERISTICS(Ta=25 °C)

LED

ITEM	SYMBOL	CONDITION	MIN.	TYP.	MAX.	UNIT
Supply Voltage	V _{LED}		3.9	4.2	4.5	V
Luminous	I _V		80			cd/m ²