

YMS240128-01

240 x 128DOTS
1/128DUTY, 1/12BIAS

1 EXTERNAL DIMENSION AND DISPLAY PATTERN

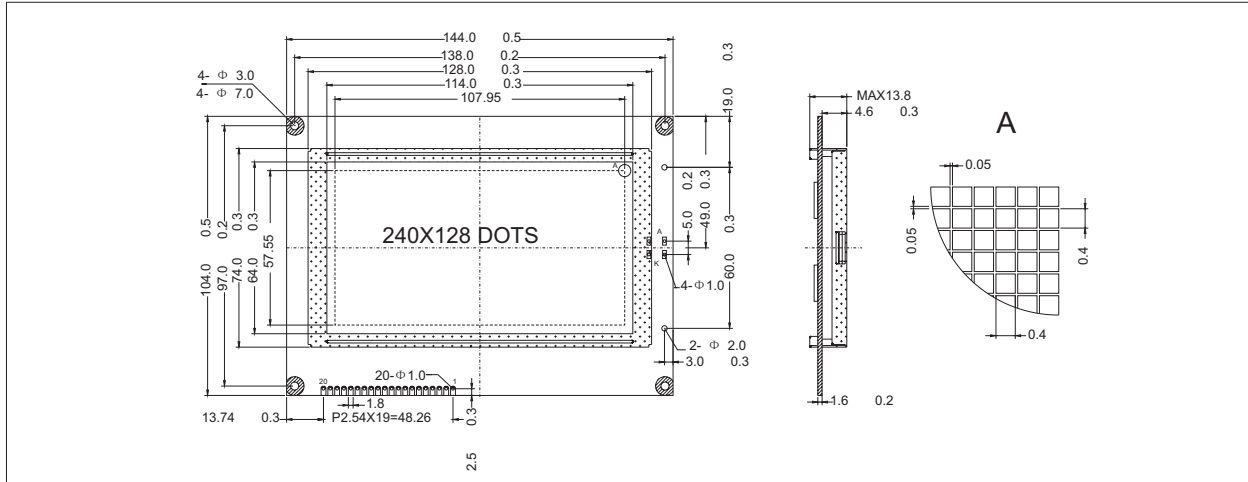

2 MECHANICAL DATA

ITEM	SPECIFICATION	UNIT
Module Size(WXHXT)	144.0 x 104.0 x 13.8	mm
Viewing Area(WXH)	114.0 x 64.0	mm
Number of Dots	240 x 128	dots
Dot Pitch (WXH)	0.45 x 0.45	mm
Dot Size(WXH)	0.4 x 0.4	mm

3 PIN CONFIGURATION

PIN	SYMBOL	LEVEL	SIGNAL DESCRIPTION
1	V _{SS}	0V	GND(0V)
2	V _{DD}	+5V	Supply Voltage for Logic and LCD
3	V _o	-	Operating Voltage for LCD (Variable)
4	C/D	H/L	H:Instruction Code,L:Data Code
5	/RD	L	Read Signal
6	/WR	L	Write Signal
7	DB0	H/L	Data Bit 0
8	DB1	H/L	Data Bit 1
9	DB2	H/L	Data Bit 2
10	DB3	H/L	Data Bit 3
11	DB4	H/L	Data Bit 4
12	DB5	H/L	Data Bit 5
13	DB6	H/L	Data Bit 6
14	DB7	H/L	Data Bit 7
15	/CE	L	Chip Enable Signal
16	/RES	H,H-L	Reset Signal
17	V _{DD}	-	Supply Voltage LCD Driver
18	MD2	H/L	Number of Columns Select Signal
19	FS1	H/L	Font Select Signal(H:6 x 8Dots,L:8 x 8 Dots)
20	NC	-	No Connection
21	A	-	Anode of LED Unit
22	K	-	Cathode of LED Unit

4 BLOCK DIAGRAM

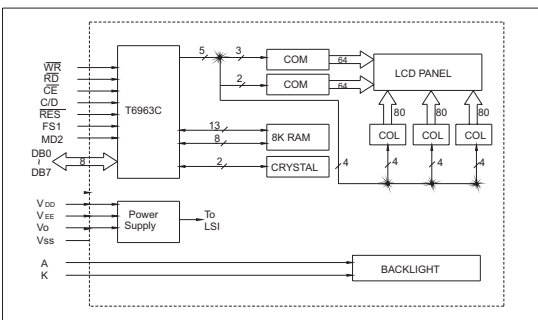

5 ABSOLUTE MAXIMUM RATINGS

PARAMETER	SYMBOL	MIN.	MAX.	UNIT
Supply Voltage Logic	V _{DD} (V _{DD} -V _{SS})	-0.3	7.0	V
Supply Voltage Driver	V _{DD} -V _{EE}	-0.3	30.0	V
Input Voltage	V _{IN}	-0.3	V _{DD} +0.3	V
Operating Temp.		See page 9		
Storage Temp.		See page 9		

6 ELECTRICAL CHARACTERISTICS(Ta=25 °C)

ITEM	SYMBOL	CONDITION	SPEC. VALUE			UNIT
			MIN.	TYP.	MAX.	
Supply Voltage (Logic)	V _{DD} -V _{SS}		4.5	5.0	5.5	V
Supply Current (Logic)	I _{DD}	V _{DD} =5V	-	8.7	13.0	mA
Input Voltage	"HIGH"	V _{IH}	-	V _{DD} -2.2	-	V _{DD} V
	"LOW"	V _{IL}	-	0	-	0.8 V
Output Voltage	"HIGH"	V _{OH}	I _{OL} =3.0mA	V _{DD} -0.3	-	V _{DD} V
	"LOW"	V _{OL}	I _{OL} =3.0mA	0	-	0.3 V
LCD Operating Voltage	V _{DD} -V _o	V _{DD} =5V	-	16.6	-	V
Supply Voltage LCD Drive	I _o	Ta=25 °C	-	5.47	-	mA

Note(1): () Value is high Reliability type
Note(2): Electro-Optical Characteristics: See page 6.

7 BACKLIGHT CHARACTERISTICS(Ta=25 °C)

ITEM	SYMBOL	CONDITION	MIN.	TYP.	MAX.	UNIT
Supply Voltage	V _{LED}	-	3.6	4.1	4.5	V
Power Consumption	P _{LED}	IF=720mA	-	2950	-	mW
Luminous	I _v	IF=720mA	133	190	-	cd/m ²

8 SWITCHING TIMEING CHARACTERISTICS

PARAMETER	SYMBOL	MIN.	MAX.	UNIT
CD SET Up Time	t _{CSU}	100	-	ns
CD Hold Time	t _{CH}	10	-	ns
ICE/RD/WR Puls Width	t _{CE} , t _{RD} , t _{WE}	80	-	ns
Data Set Up Time	t _{DSU}	80	-	ns
Data Hold time	t _{DH}	40	-	ns
Access time	t _{ACC}	-	150	ns
Output Hold time	t _{OH}	10	50	ns

Condition: V_{DD}=5V, 10%V_{DD}=0.5V, 25 °C

